

# Grid Stabilization

We make the energy transition happen



**Wind turbines**

**Electrolyser**

**Batteries and storage solutions**

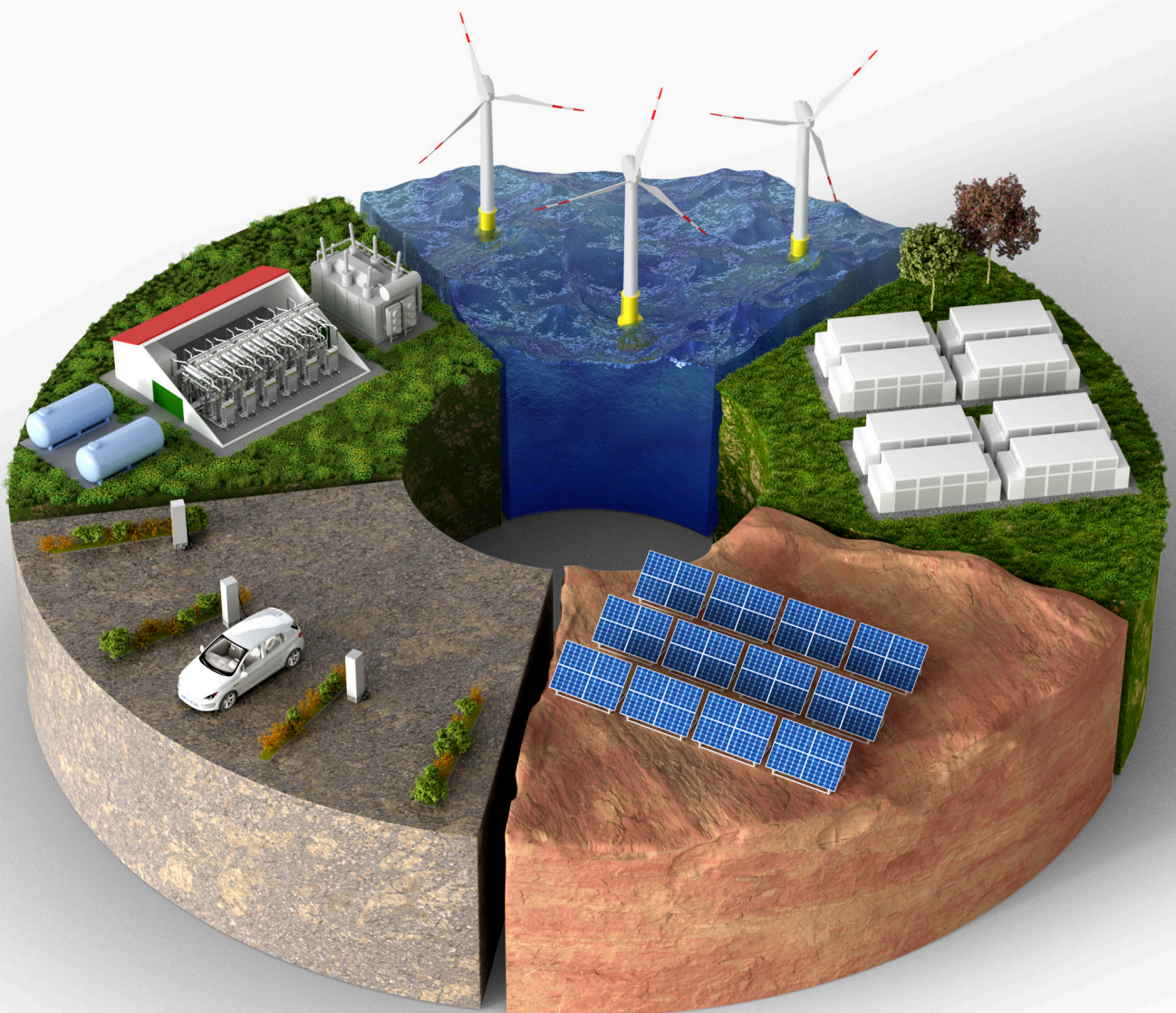

**E-mobility**

**Solar panels**

# 1 Challenges in changing grids

Page 4

## 2 Complexity in grid stabilizing

Page 8

- 2.1 Voltage stability
- 2.2 Frequency stability
- 2.3 Load flow management

## 3 Pathways to solutions

Page 12

- 3.1 Our approach
- 3.2 Grid consulting – from grid challenge to the solution
- 3.3 We'll be there for you – around all your needs

## 4 Grid stabilizing technology

Page 18

- 4.1 State-of-the-art approach
- 4.2 SVC PLUS®

- 4.3 SVC PLUS FS® (Frequency Stabilizer)
- 4.4 Synchronous Condenser
- 4.5 MVDC PLUS®
- 4.6 UPFC PLUS®
- 4.7 Fixed Series Capacitor

## 5 Global references

Page 36

- 5.1 SVC PLUS® – Kriftel, Germany
- 5.2 SVC PLUS® – Sortland, Norway
- 5.3 SVC PLUS FS® – Mehrum, Germany
- 5.4 SynCon – Robertstown, Australia
- 5.5 SynCon – Oberottmarshausen, Germany
- 5.6 SynCon – Moneypoint, Ireland
- 5.7 FSC – Castanhal, Brazil
- 5.8 FSC – Hirvisuo, Finland
- 5.9 FSC – Polpaico, Chile

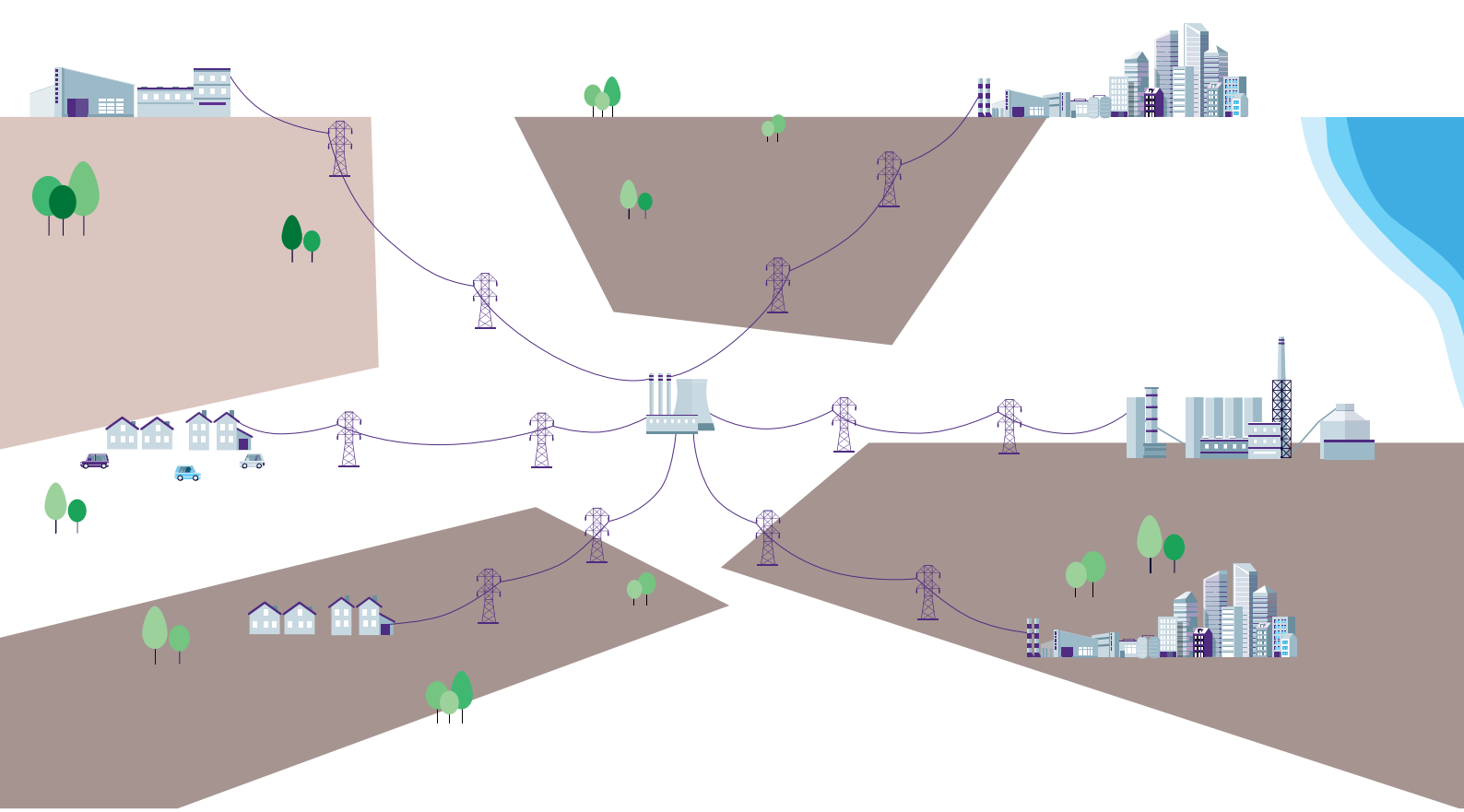

Transforming HV-grids from conventional...

# 1. Challenges in changing grids

The worldwide power sector has witnessed significant disruption, growth, and change in recent years. Three components driving these developments include decarbonization, electrification, and the increasing liberalization of energy markets. On the generation side, integrating renewable energy sources, mainly photovoltaic and wind power, alters the operation of conventional power systems. One factor is the intermittent nature of renewable energy sources. In addition, associated technologies have power electronics at the grid interface, decreasing overall inertia due to a lack of rotating masses directly connected to the grid. This issue is exacerbated by the increasing demand for electricity and the need for stronger interconnections between power systems.

These factors pose new challenges for grid stability along three domains: voltage stability, frequency stability, and load flow management.

## Voltage stability

The system voltage must be maintained within allowable voltage ranges to ensure stable power system operation and safeguard people, equipment, and consumer devices. A sufficient supply of reactive power is needed to maintain voltage stability and leverage the transmission capacity of existing transformers and lines. Both in transmission and distribution grids, voltage stability requirements increase in transmission and distribution grids, compared to a corresponding decrease in conventional power plants. Therefore, more grid services must be used.

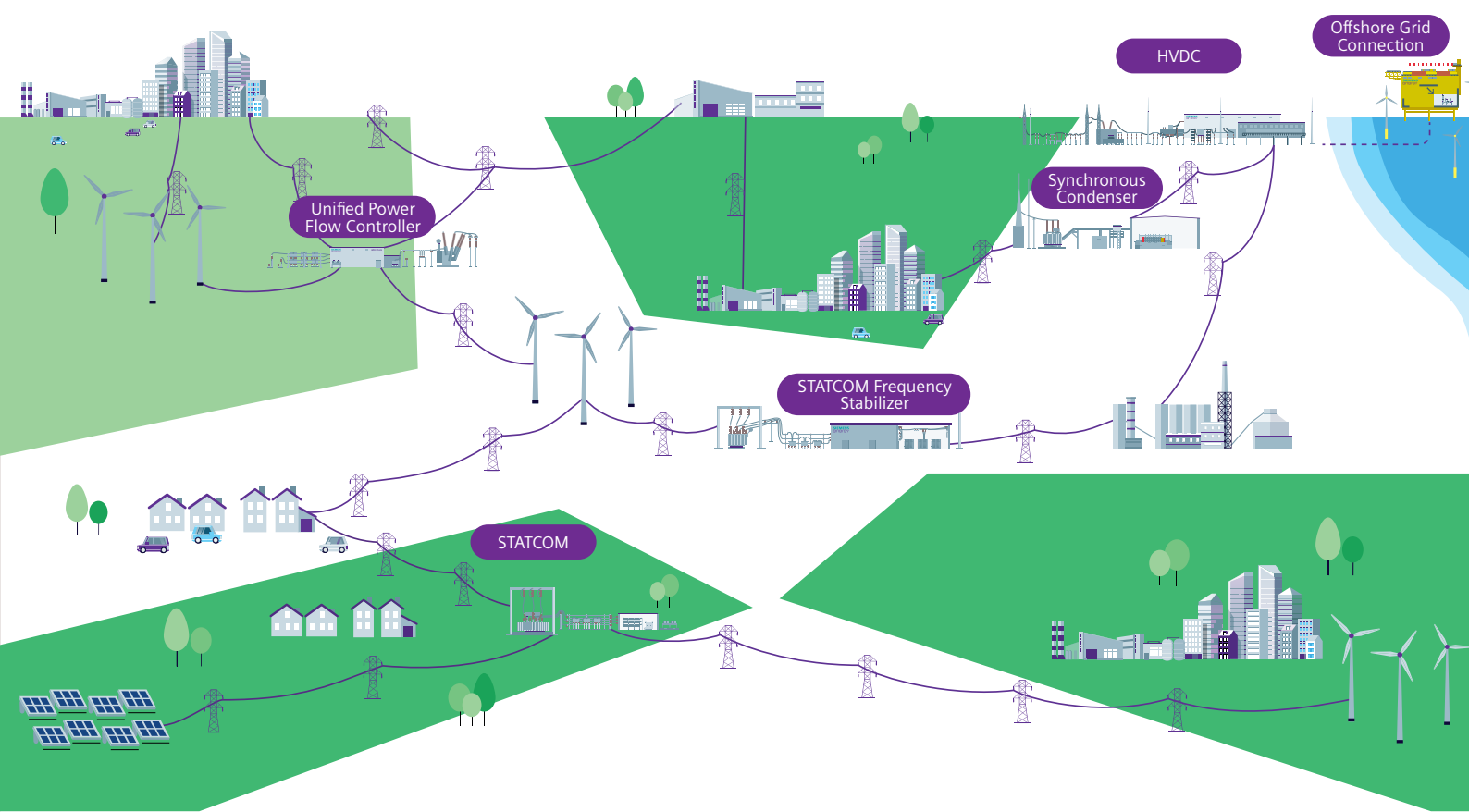

Siemens Energy transmission solution

...to decarbonized and renewable power supply

**Frequency stability**

Frequency control ensures that power fed into the grid corresponds with power consumption, as any deviations in the total balance can result in a change in frequency. The transmission system operator must quickly return the required frequency to the rated value and can do so with the help of grid service products.

The rising fluctuation in generation capacity due to renewables has led to the increased demand for grid services.

**Load flow management**

Power system supply and demand must be kept in balance. Thermal overloads in power transmission lines and a growing number of instances in which frequency and voltage approach critically acceptable range limits –

or even exceed them – may require costly redispatch interventions to resolve current and voltage factors. System operators must optimize the utilization of transmission lines to get the most from existing grid capacity while maintaining maximum protection, reducing the risk of power failures, and minimizing redispatch costs.

**Increasing complexity**

To manage these interrelated factors, grid operators are looking for flexible, scalable solutions that fit within local requirements in terms of energy supply areas.

# Trends in electric energy supply

- Shutdown of conventional fossil and nuclear power plants
- Large-scale integration of renewables
- Increasing power demand in existing grids
- Continuous evolution of power market rules and regulations

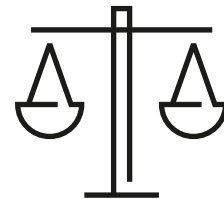
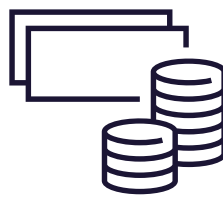
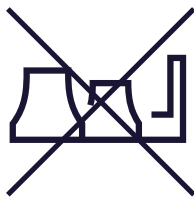

# ...cause grid stability risks

- Decreases grid strength and frequency stability
- Increases inverter-connected generation
- Decreases voltage stability
- Increases unbalanced load flows, congestion, and redispatch

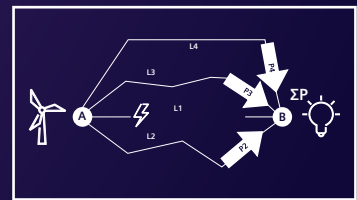
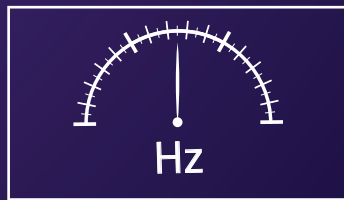
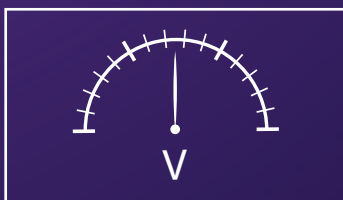

# 2. Complexity in grid stabilizing

The challenges within frequency stability, voltage stability, and load flow management are highly complex. System services available to support reliable grid operation are detailed in the following table.

Voltage stability <span style="float: right;">[v]</span>	Frequency stability <span style="float: right;">[f]</span>	Load flow management <span style="float: right;">[p]</span>
<p><b>Dynamic voltage control</b> To ensure voltage stability at any time, reactive power output is controlled with a fast response time.</p>	<p><b>Inertia contribution</b> When large rotating generators that previously provided inertia are replaced by non-synchronous generation, inertia must come from other sources.</p>	<p><b>Dynamic load flow control</b> Volatile renewable generation may cause temporary overload of certain power lines and must be avoided.</p>
<p><b>Stationary voltage control</b> To react to slow grid changes, the full output range will be provided, initiated by the control system or manually by the operator.</p>	<p><b>Fast frequency response</b> If the frequency suddenly deviates from its nominal value, additional power is needed immediately.</p>	<p><b>Stationary load flow control</b> Adding power generation into the grid can overload power lines, while freeing capacity for others.</p>
<p><b>Active filtering</b> Modern semiconductors promote flexibility and utilization of the remaining capacity in the operating range to actively filter existing background grid harmonics.</p>	<p><b>Primary frequency response</b> If the fast frequency response does not resolve the frequency deviation, additional measures must be taken with an increased amount of active power.</p>	<p><b>Grid coupling</b> If two non-synchronized grids are connected, an intermediate circuit is needed.</p>
	<p><b>Short circuit contribution</b> In case of a fault in the grid, short circuit power is needed to avert a system-wide voltage collapse and enable the protection equipment to detect the fault.</p>	<p><b>Power oscillation</b> If power oscillation is detected, the control system will automatically mitigate power swings.</p>
	<p><b>Grid forming capability</b> Converters exhibiting voltage source behavior for grid stability provide instantaneous power (reserve), ensuring stable operation at low short circuit levels.</p>	<p><b>Sub-synchronous resonance</b> To protect the large power generator shafts, torsional interaction should be avoided; if this occurs, additional measures must be taken.</p>



## 2.1 Voltage stability

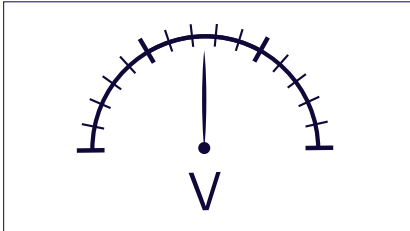

Stable operation

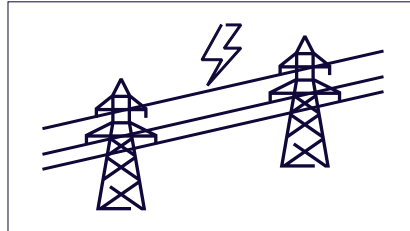

Event

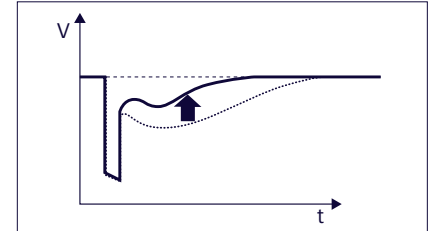

Restabilization

**V** When talking about voltage stability, many aspects play a role. All consumer and electrical devices work at a specified voltage. Malfunction or damage to these devices can occur due to under or overvoltage. Keeping the voltage stable means keeping the voltage in the allowed bandwidth for which the devices in the electrical system are designed. Voltage stability is also essential for dynamic events in networks such as faults, where the voltage may collapse for a short time and recover after fault clearing. If the recovery takes too long or does not fully recover, there may be system brownouts or blackouts.

The topic of voltage stability is not new and has been prevalent since we have electrical systems. There were always measures to stabilize voltages, and electrical systems were optimized to avoid outages and increase system availability.

These measures were based on the system topologies we had in the past, where power

generation was centralized and close to the big loads. Decarbonization goals lead to a shift in the way we generate power. There is a transition from known big centralized to smaller decentralized power generation, which is challenging to manage.

Changing how we generate power also changes the transmission systems and their physical topology. Decarbonization-based changes also impact voltage stability in the systems mainly because the system changes. We transmit power over longer distances, as renewable sources are not always close to large consumers. In addition, voltage stability is impacted by the volatility of renewable sources. Voltage stability in modern power system topologies is a considerable challenge – and dynamic reactive power compensation is the solution to tackle it and make decarbonization possible.

## 2.2 Frequency stability

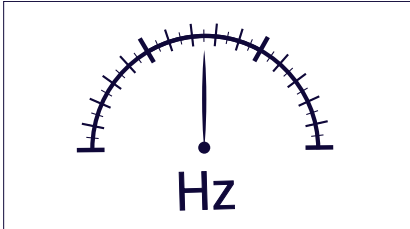

Stable operation

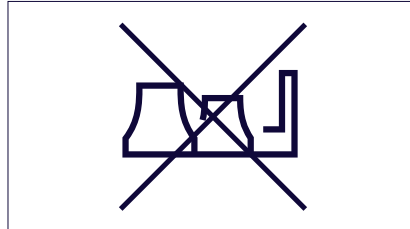

Event

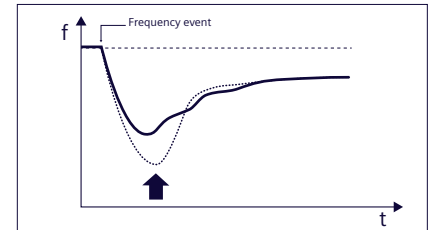

Restabilization

**f** Like voltage stability, it is critical to keep the frequency of a power system stable. Over- or under-frequency leads to malfunctions and can also cause system shutdowns. Conventional power plant generators control the frequency in power systems, where the sum of the rotating mass of generators and turbines measures the strength of the system frequency.

However, the frequency is not always constant due to minor mismatches between generation and consumption. These discrepancies happen continuously when loads are disconnected and generation needs to be reduced. The strength of the system frequency, called system inertia, measures the system's sensitivity to these mismatches.

Today, we see a change in power generation where more power is generated based on power electronic converters than conventional power plants with large rotating masses. The reduction of rotating masses –and therefore system frequency strength – leads to higher deviations from the nominal frequency in generation and consumption mismatches.

Frequency stabilizing solutions are necessary to maintain the frequency within acceptable limits, especially during high converter based generation.

## 2.3 Load flow management

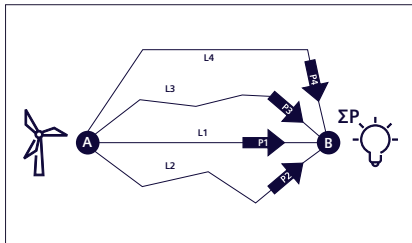

Stable operation

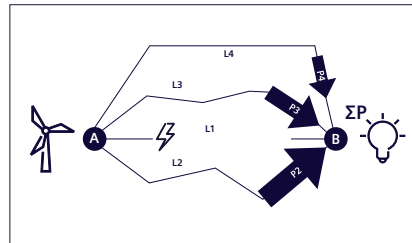

Event

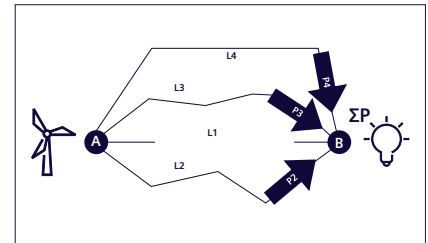

Restabilization

**P** An electric power system consists of interconnected transmission and distribution lines carrying energy from points of generation to consumption. It is crucial to perform load flow planning for all possible scenarios, as grid components can only withstand a certain amount of current. Transmission grid operation follows the N-1 criterion in which electrical components do not operate at maximum thermal capacity to withstand scenarios where one line is out of service, and other parts must assume power flow on top of their regular loading. Following this criterion ensures reliable and secure grid operation, especially for system faults.

As the load flow in power systems is becoming increasingly complex, we must account for even more scenarios. Volatile generation from renewable energy sources directly impacts line loading, but system underutilization remains a point of discussion. Due to the growth of renewables and increased energy needs, optimal utilization of all assets is imperative.

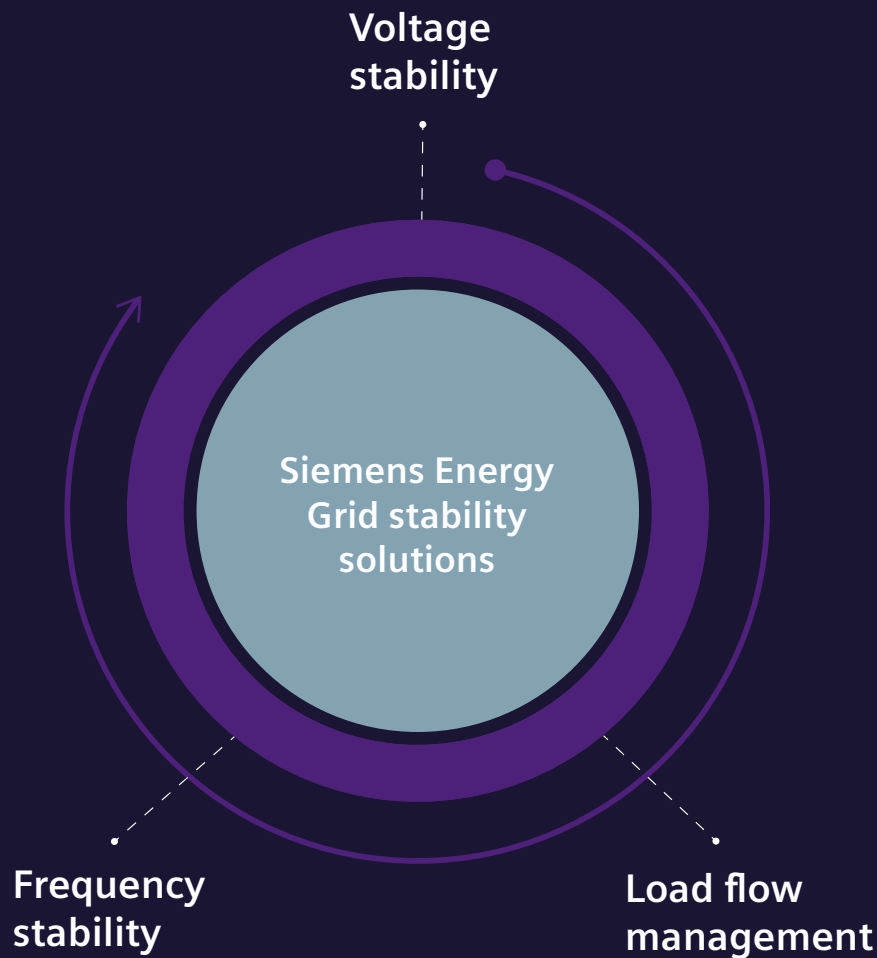

## 3. Pathways to solutions

Power generation now utilizes more efficient and environmentally friendly technologies. Given the changes in power consumption sites, HV grids must use state-of-the-art technologies to provide essential stability and reliability.

### 3.1 Our approach

As a leader in the power transmission industry, Siemens Energy has developed modern, flexible, high-capacity grid stabilizing solutions, including Flexible AC Transmission Systems (FACTS), to prevent high voltage fluctuations and power

failures, optimize network asset utilization, and mitigate load-induced disturbances. Our solutions efficiently and reliably regulate voltage, impedance, and phase angle, providing inertia and short-circuit power.

## Grid stabilizing solutions

At Siemens Energy, we provide grid stabilization solutions to address even the most complex problems and network instability. We are also developing new solutions to manage current and future grid challenges while improving transmission system stability and performance.

With our grid stabilizing solutions, power companies can better utilize their existing transmission networks, substantially increase the availability and reliability of their line networks, and improve dynamic and transient network stability while ensuring a better quality of supply. The table below highlights some solutions offered by Siemens Energy.

		Technology						
		System service	SVC PLUS®	SVC PLUS FS®	SynCon	MVDC PLUS®	UPFC PLUS®	FSC
Voltage stability <span>V</span>	Dynamic voltage control	✓	✓	✓	✓	✓	✓	✗
	Stationary voltage control	✓	✓	✓	✓	✓	✓	✗
	Active filtering	✓	✓	✗	✓	✓	✓	✗
Frequency stability <span>f</span>	Inertia contribution	✗	✓	✓	✗	✗	✗	✗
	Grid forming	✓	✓	✓	✓	✓	✓	✗
	Fast frequency response	✗	✓	✗	✓	✗	✗	✗
	Primary frequency response	✗	✗	✗	✓	✗	✗	✗
	Short circuit contribution	✗	✗	✓	✗	✗	✗	✗
Load flow management <span>P</span>	Dynamic load flow control	✗	✗	✗	✓	✓	✗	✗
	Stationary load flow control	✗	✗	✗	✓	✓	✓	✓
	Grid coupling	✗	✗	✗	✓	✗	✗	✗
	POD / SSR damping	✓	✓	✗	✓	✓	✓	✗

## 3.2 Grid consulting – from grid challenge to the solution

Moving from the identification of grid challenges to the optimal solution definition is not always trivial, as many questions arise:

- Which grid stabilizing devices are the best choice?
- How large should they be, and how many are needed?
- Which locations in the grid should they be installed?
- When are they required, and how do they fit into the long-term grid development plan?

Applying simulation-based studies and using their grid expertise and extensive product knowledge, our highly experienced team of grid consultants can answer these questions and guide you toward a tailor-made solution.

These services range from initial optioneering and component selection to full-scale long-term grid development masterplans, as shown in the portfolio overview below.

### Strategic grid planning

Data- and simulation-driven decision support

Study  
portfolio

#### Model development

Digital representation  
of transmission and  
generation assets

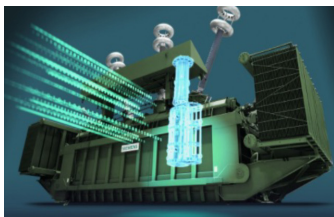

#### Solution design

Dimensions, selection,  
design, and verification  
of transmission and  
generation solutions



#### Grid integration

Grid interconnection of  
transmission and generation  
technologies





Amprion's STATCOM substation in Kriefel to support the power supply for the greater Frankfurt area in Germany with its almost six million inhabitants.

## What our customers say

**„The ongoing energy transition leads to substantial new challenges for the safe operation of our transmission grid. This need is covered by the increased use of grid stabilizing solutions, such as synchronous condensers with additional flywheels, and STATCOMs with multiuse capabilities. For the future we see a further need for new solutions providing instantaneous reserve and for grid forming control concepts. With its technical expertise and innovative capabilities, Siemens Energy is an important partner for our journey towards a green future.”**

Dr. Daniel Eichhoff, Grid Projects, Senior Manager Substations, Amprion



### 3.3 We'll be there for you – around all your needs

From the early phases throughout the lifecycle, Siemens Energy is your reliable partner and ensures no gaps in the full cycle. Our in-house capability minimizes risk across all phases of the project.





Siemens Energy offers a single source for all necessary grid stabilizing solutions and a comprehensive range of complementary services, including system design, modeling, network analyses, civil works, project management, functional performance tests, delivery, and installation. In addition, we assist with commissioning, onsite tests, and training of operating personnel.

Siemens Energy analyzes and calculates the power system requirements, develops customized solutions for complete system

configurations and plants, and quickly implements them. Siemens Energy can deliver turnkey solutions and create new solutions, enabling timely grid stability improvements in rapidly changing energy systems. We provide innovative, proven grid stabilization solutions, including in-house components. Siemens Energy offers services for nearly all customer requirements, including design studies, financing support, project management, assembly, commissioning, and after-sales service. We are your trusted partner for all project stages.

# 4. Grid stabilizing technology

Siemens Energy is the world leader in state-of-the-art grid stabilizing solutions and pioneered modular multilevel converter technology. Our grid stabilization portfolio features decades of success in solving the most complex customer challenges. Siemens Energy succeeds through our combined engineering expertise and innovative capabilities. Most importantly, common hardware and software platforms enable us to stay ahead of the technological edge.

## 4.1 State-of-the-art approach

### A wide portfolio based on the same principles - PLUS Platform

Our grid stabilization hardware solutions based on power electronics use the uniform, highly modularized PLUS platform, delivering unmatched reliability and durability.

The modular multilevel converter (MMC), introduced by Siemens Energy over a decade ago, is the reference standard for high voltage, high power voltage source converter (VSC) applications.

In Siemens Energy PLUS systems, one MMC has identical converter arms, each containing several series of connected sub-modules to form the required AC voltage. Each contributes a small voltage step and is individually controlled. A discrete voltage source with a local capacitor defines its voltage step without creating ripple voltage distortion across the MMC's other phases. This way, it can achieve the required sinusoidal AC output voltage waveforms without excessive harmonic distortion and HF noise.



Power module

The insulated-gate bipolar transistors (IGBTs) at the core of the sub-modules are fully controllable. The output currents can be varied over the entire operating range smoothly and linearly. This feature enables independent and flexible control of active and reactive power to support the connected AC grid.

By changing the number of sub-modules and their electrical interconnections, Siemens Energy's grid stabilization solutions deliver a variety of converter configurations. Standardized electrical and mechanical designs for different converter sizes ensure maximum safety and an optimal footprint of the overall plant.

Siemens Energy has over a decade of expertise in grid integration of MMC technology. From day one, we developed and refined our solutions and will continue to do so.

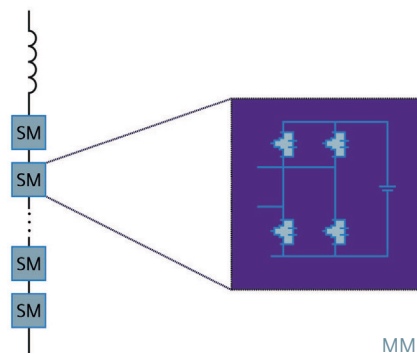

MMC branch

Our goal is to offer solutions based on the same field-proven hardware while providing reliable grid stabilization.

Siemens Energy recognizes that new challenges in the high-voltage grid will have to be met by system operators in the future and is constantly developing new solutions. All of our new power electronics-based solutions will incorporate the PLUS platform.

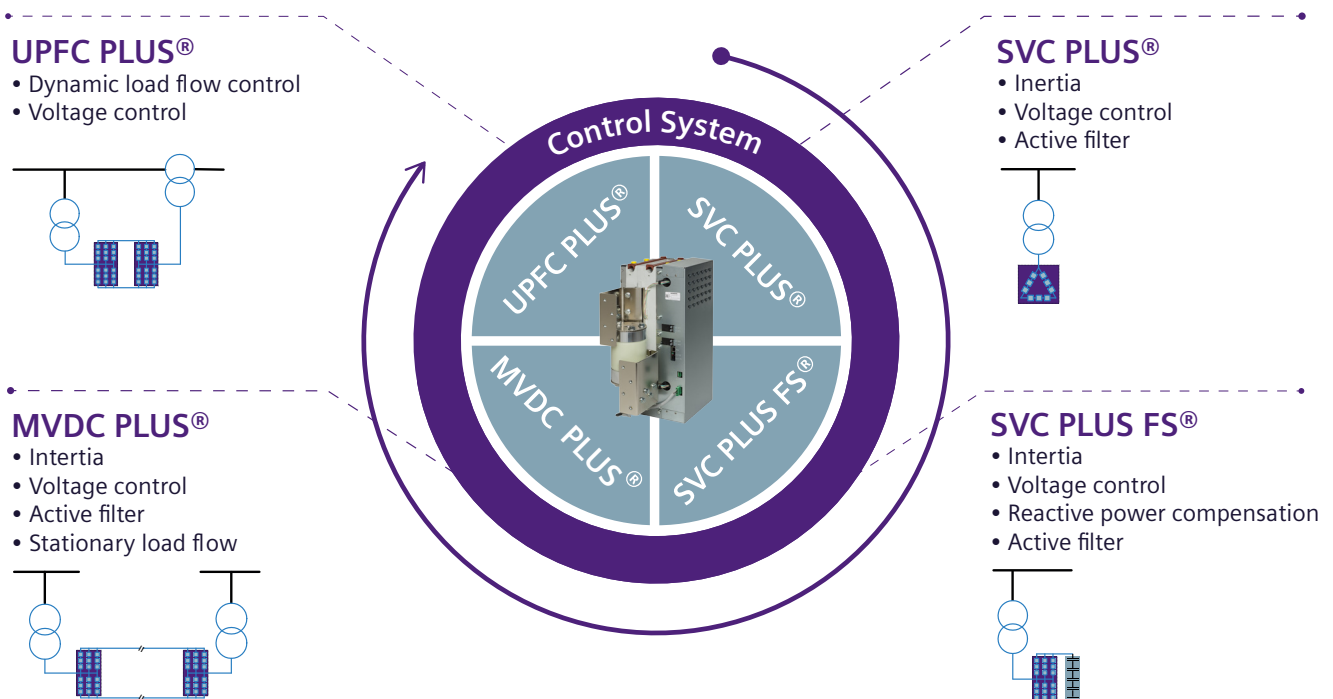

Overview of some Siemens Energy's grid stabilization solutions based on power electronics

## The new control and protection platform

Control and protection (C&P) systems are critical to managing power flows and protecting grid components in FACTS plants. Both are paramount in light of increasingly complex grid architectures and fluctuating power infeed from renewable energy sources. As a result, system operators must contend with three main challenges. The first involves a quick reaction to market needs and the short lead time of the C&P system. The second pertains to reliable and secure operations throughout the entire lifecycle while safeguarding the low total cost of ownership. Lastly, the C&P system should allow for the easy expansion of new solutions and services. Addressing these challenges is crucial to managing the ongoing energy system transformation and leveraging future innovations.

### Modularity meets reliability

With our new modular C&P platform, Siemens Energy is tackling these challenges head-on. Our platform approach provides a common, proven, reliable basis for applications, processes, products, and technologies. Our pre-integrated and ready-to-use reference projects – called reference project lines – allow us to configure customer-specific solutions following your performance requirements. Based on these configured reference projects, customer-specific delta engineering leads to significantly reduced engineering and lead times.

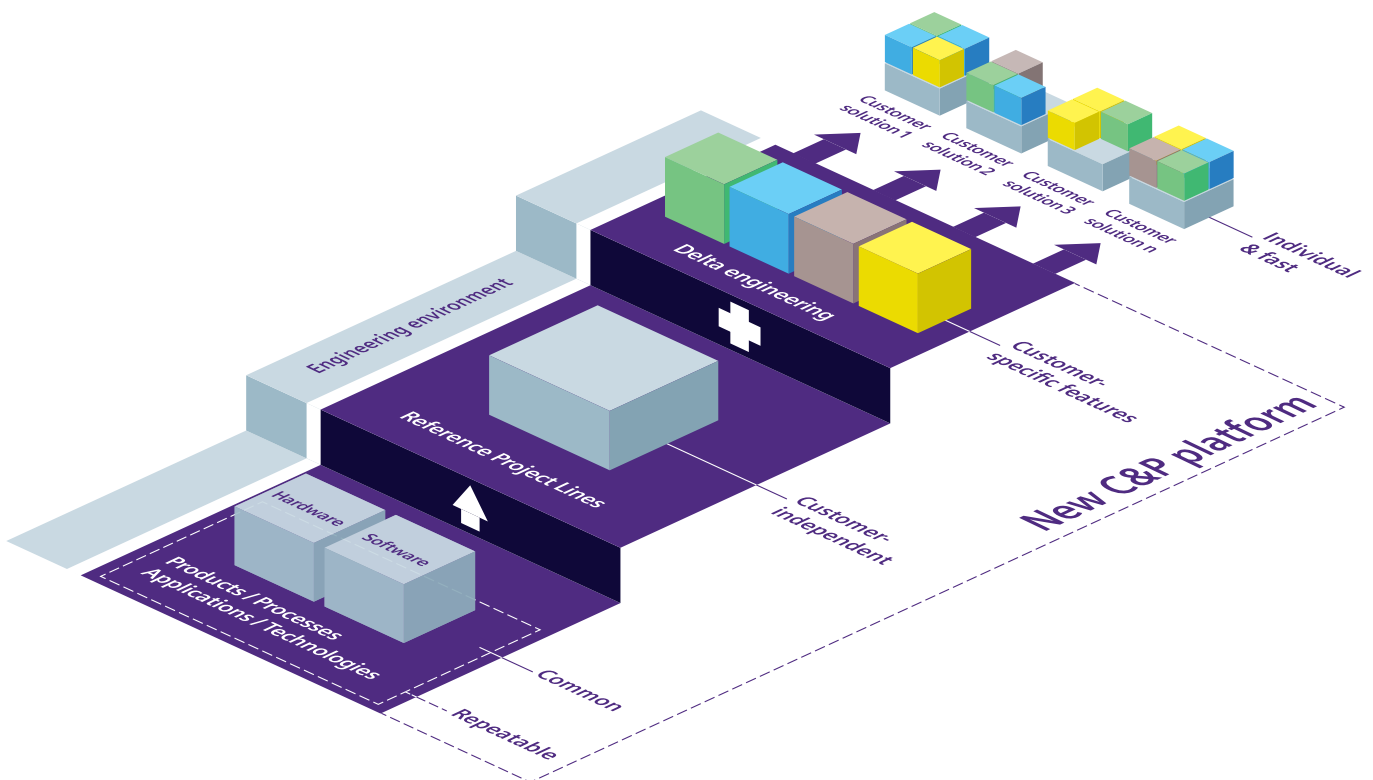

## The platform philosophy is incorporated in all areas of the system:

- Software applications for control and protection, field, and operations levels
- Hardware for control and protection, communications, field, and operations levels
- An open and digitalized engineering ecosystem

### Software applications

Our state-of-the-art methods and tools increase software development speed, efficiency, and accuracy. One such method is **model-driven system engineering** with MATLAB® and Simulink®,<sup>1</sup> which creates a single point of code transformation, including software development, simulation, and offline testing. Functionalities can be seamlessly integrated and simulated, facilitating the identification and correction of design errors from an early stage.

The same advantage applies to the **digital twin** – tests can be performed automatically and offline without impacting the physical process.

The digital twin escorts the system from the beginning, enhancing documentation and traceability.

Throughout the development process, we generate **building blocks and functions** for reuse in other projects. Engineering starts from standardized templates using reference project lines, significantly reducing the risk of errors and allowing for project implementation in parallel. We can also leverage the advantage of **hardware-independent software development** – even with hardware changes, software applications remain usable.

<sup>1</sup> MATLAB® und Simulink® are registered trademarks of Mathworks, Inc.

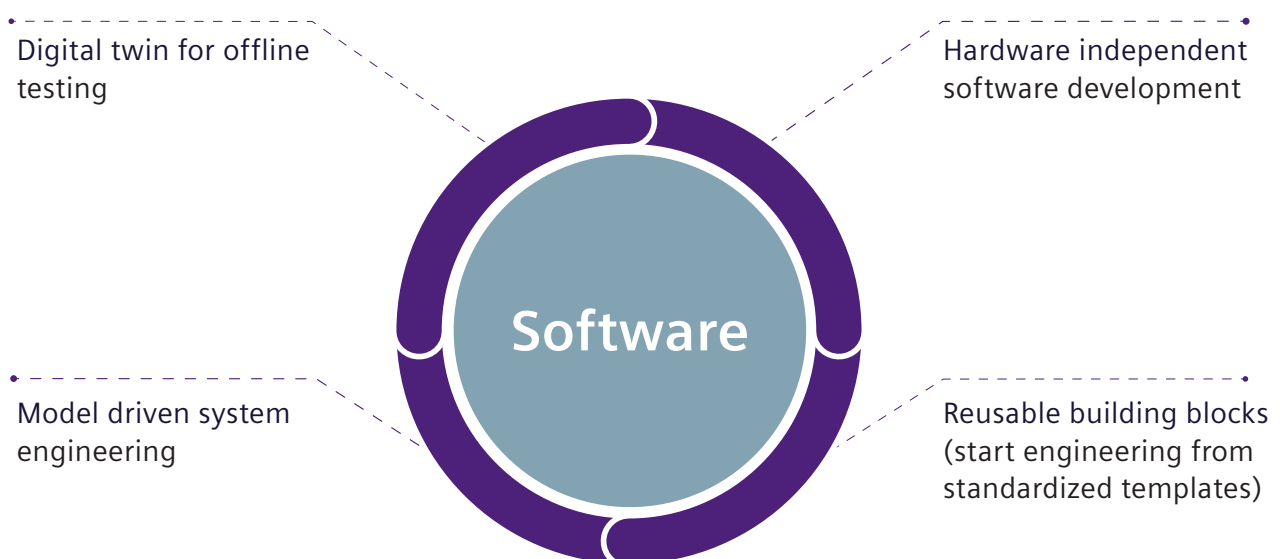

## Control-level hardware

The hardware concept at the control level focuses on quick reaction, robustness, and secure functionality and data exchange. In addition, scalable rail-mounted **PC technology** makes it easy to extend the system at any time in computing and processing power.

A wide range of internal **standard protocols**, from IEC61850 to EtherCAT, allows for fast and seamless communications. Short **bus cycle times** of up to 250µs enable closed-loop control tasks and deliver the performance to support new features.

With the ever-faster digital revolution, we've invested extensive expertise and diligence into **cyber security**. The primary hardware will run on an industrially proven open-source Unix operating system, creating a small footprint since every running service and configuration can be justified and explained. There are no dependencies on other operating systems. Thanks to open-source distribution, the functionality of the operating system and its applications can be verified, which is essential to comply with future security legislation initiatives. Continuous updates and life-long patch management complete the package.

## Engineering environment

Digitalization offers unparalleled opportunities for collaboration, co-creation, and stakeholder involvement. With the new C&P platform, we are leveraging this potential to accelerate engineering and execution – for the benefit of all.

The **plant data digital twin** is a common data backbone for agile collaboration throughout the lifecycle. With the **cloud-based engineering portal**, all stakeholders in the engineering process gain full transparency and access to current and accurate data, enabling them to work in parallel. The underlying **common cloud infrastructure** enabled by a DevOps mindset and principles helps manage the build and release process and promotes fast deployment – a crucial aspect to react to and seize the potential of the energy transformation.

However, it is not only about engineering speed – equally important is operative reliability. With SensOTS, a **cloud-based operator training simulator**, staff can be trained in advance to operate the C&P system, “read” data if using the option for analytics, and manage condition-based maintenance.

## Digital engineering and execution platform

The third component of our state-of-the-art approach is common processes with a high degree of engineering digitalization and project execution.

Digitalization has a profound impact on the way we can deliver projects. Siemens Energy offers the complete package, including project management and engineering. Using the latest

digital management and engineering methods, we provide endless flexibility in collaboration and communication, ensuring a seamless and successful experience for our customers and partners.

Digital engineering and execution mean working with all stakeholders on a common data platform for agile project collaboration and efficient

operation, enabling the reduction of execution time and steps, data exchange and access in the cloud, and improved efficiency. Digital engineering and execution also facilitate collaboration between different project stakeholders, reduce project lead time and risk, and increase data safety.

Examples of digital engineering and execution platform use include building information modeling (BIM) applications for planning,

design, and construction (e.g., 4D time scheduling, 3D modeling, design, collaboration) and modeling tools for simulation (e.g., plant noise simulations).

The following figure presents an overview of the complex global digital cooperation for state-of-the-art digital operations. The use of digital tools for engineering accelerates project delivery and establishes maximum transparency for all stakeholders involved in the project.

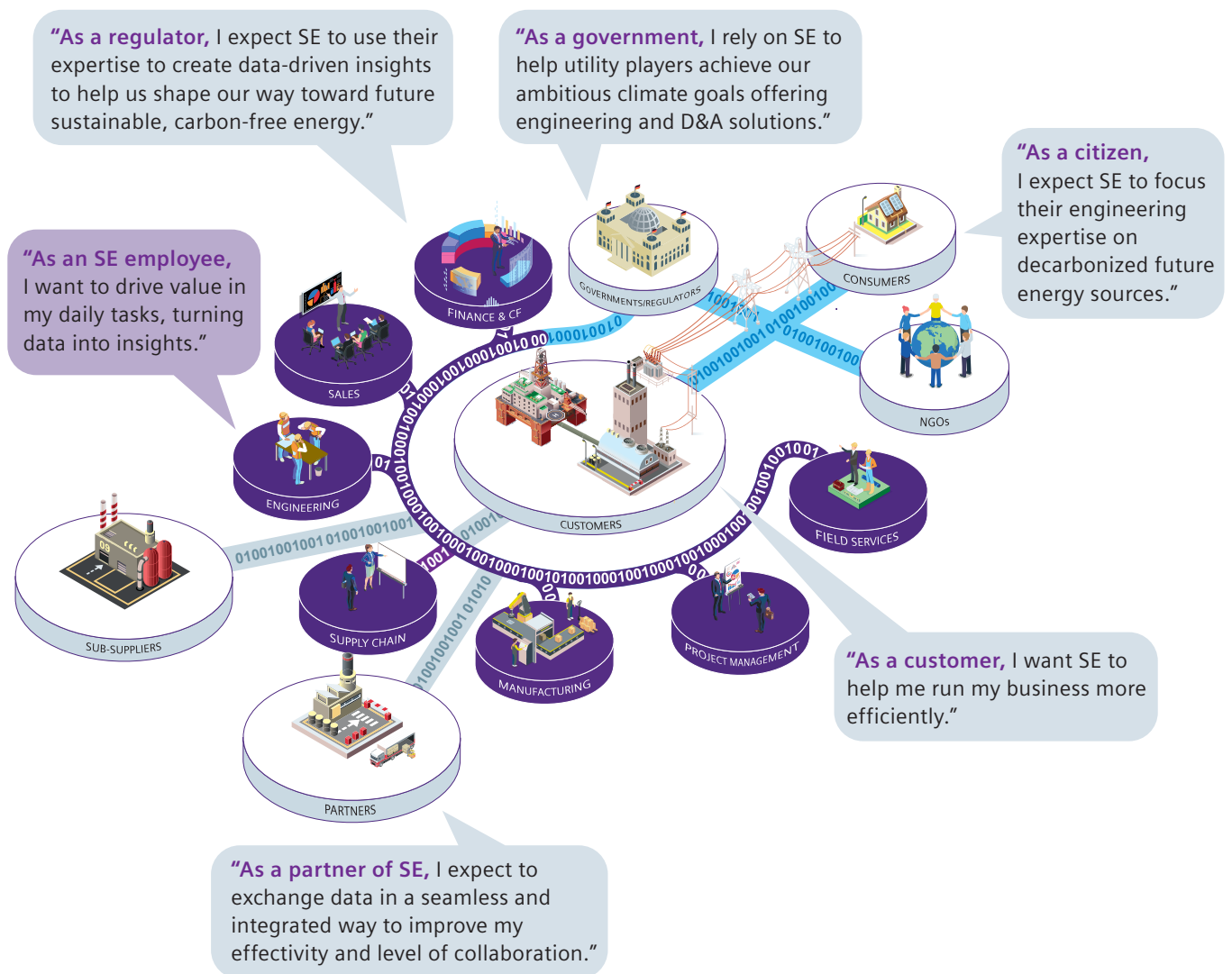



## 4.2 SVC PLUS®

Static synchronous compensator (STATCOM) technology is a dynamic solution for voltage control in the power grid by injecting and absorbing reactive power. Siemens Energy created the latest technological development – modular multilevel STATCOM, or SVC PLUS® – to offer optimal performance to our customers.

### Based on high-performance IGBT transistors

SVC PLUS® is the leading technology in reactive power compensation and is based on VSC technology, using high-performance transistors (IGBTs) as the primary semiconductor device. This modular multilevel system has several advantages compared to previous STATCOM configurations:

- IGBT switching frequency is significantly decreased, resulting in low electrical losses and less stress on components, increasing equipment lifetimes.
- The waveform produced as output is almost ideally sinusoidal, nearly eliminating the need for filtering due to the negligible amount of harmonics generated by SVC PLUS®.
- The number of outdoor components is dramatically reduced for a compact footprint and efficient use of space.

### Systematically improved under-voltage performance

The electrical characteristics of SVC PLUS® differ from a classic SVC. SVC PLUS® output power is proportional to the system voltage, while a classic SVC's output is proportional to the voltage squared. SVC PLUS® current control delivers superior under-voltage performance, supporting the network longer and at lower voltages.

In addition, the built-in IGBTs can operate during a temporary overload, providing up to 25% more power for 2 s – an absolute advantage during severe network contingencies. SVC PLUS® delivers more output power and stability, yet also comes in a smaller form factor than a classic SVC while still achieving the same output.



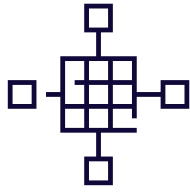

Optimal stability and quality

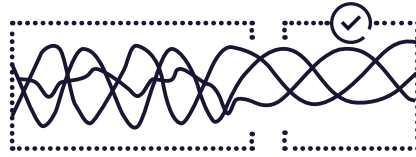

In harmony with harmonics – and best flicker reduction

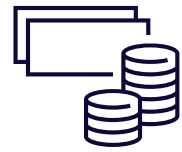

Fastest response – efficient solution

Benefits

**The SVC PLUS® can be used for:**

- Fast voltage control under various load conditions during steady-state and dynamic events
- Reactive power control
- Unbalance control
- Power factor regulation
- Power oscillation damping
- Improved flicker reduction in industrial applications

With more than 80 high power range installations on all continents and many years of collective experience, SVC PLUS® is a proven and trusted technology.

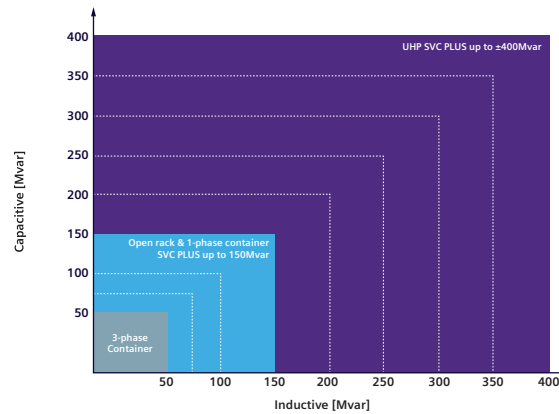

Siemens Energy introduced SVC PLUS® nearly 10 years ago, and the technology has since garnered tremendous attention and appreciation across the industry.

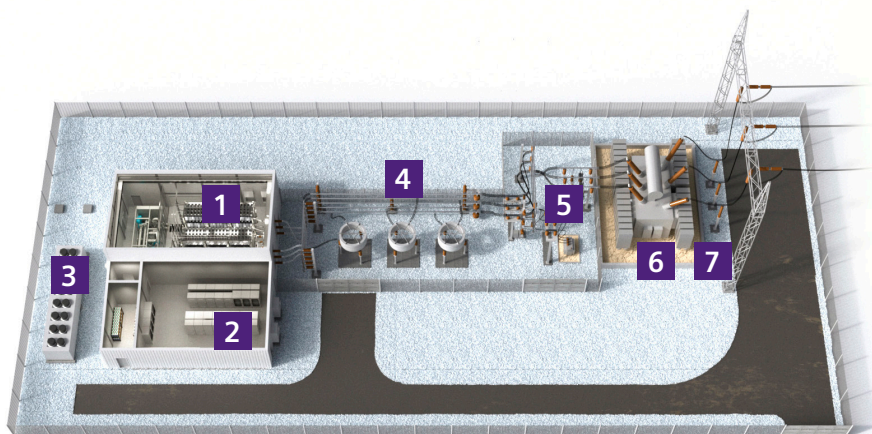

- 1 SVC PLUS converter
- 2 Control room
- 3 Cooling
- 4 Phase reactor yard
- 5 MV switchyard
- 6 Power HV/MV transformer
- 7 Connection to the HV switchyard

SVC PLUS Overview



## 4.3 SVC PLUS FS<sup>®</sup> (Frequency Stabilizer)

STATCOM solution with voltage and frequency control in one unit.

### The challenge

While grids are undergoing fundamental changes in power generation, renewable infeed, and ever-increasing demand, power quality and dynamic grid stability are at risk due to less synchronous power generation.

As the power infeed from inverter-based resources continues to replace conventional synchronous power generation, the grid frequency is becoming more sensitive due to the reduced amount of rotating machines. Grid operators face the challenge of providing sufficient system inertia with rotating equipment to stabilize the grid. Because inverter-based resources have minimal inertia and cannot be used for frequency stabilization, new solutions are needed.

### SVC PLUS FS<sup>®</sup>: A STATCOM solution providing active and reactive power

Using a bulk number of supercapacitors, the new SVC PLUS frequency stabilizer<sup>®</sup> (FS) is a cost-efficient, compact solution supporting voltage and frequency grid stability.

- Grid forming converter: Voltage source behavior provides phase-correct instantaneous response to voltage magnitude or phase angle changes
- Energy reserves: A bulk number of supercapacitors provide grid-scale active power output, up from milliseconds to several seconds

Technical data	Configuration scalable
Active power	up to +/- 300 MW
Reactive power	up to +/- 300 Mvar
Available energy	Active power out-/input for 1... 5 s depending on super-capacitor unit



### Blackout prevention

Dynamic voltage and frequency support combined in one unit for optimal power quality.



### Cost-effective solution

Low lifetime expenditures through compact, space-saving installation with high power density, low losses, and easy maintenance.



### Grid forming

Inherent response time with high active power output over several seconds.



### High flexibility

The highly adaptable solution is suitable for various applications through the flexible adjustment of control parameters.

Benefits

### The SVC PLUS FS® provides the following features:

- Steady-state and dynamic voltage control through reactive current provision
- Frequency control using active current provision at frequency deviation
- Virtual synchronous machine with natural inertial response through active power injection due to a phase-angle step of frequency gradient
- Stabilization of weak grids through voltage source behavior

- 1 Supercapacitors
- 2 SVC PLUS converter
- 3 Control room
- 4 Cooling
- 5 Phase reactor yard
- 6 MV switchyard
- 7 Power HV/MV transformer
- 8 Connection to the HV switchyard

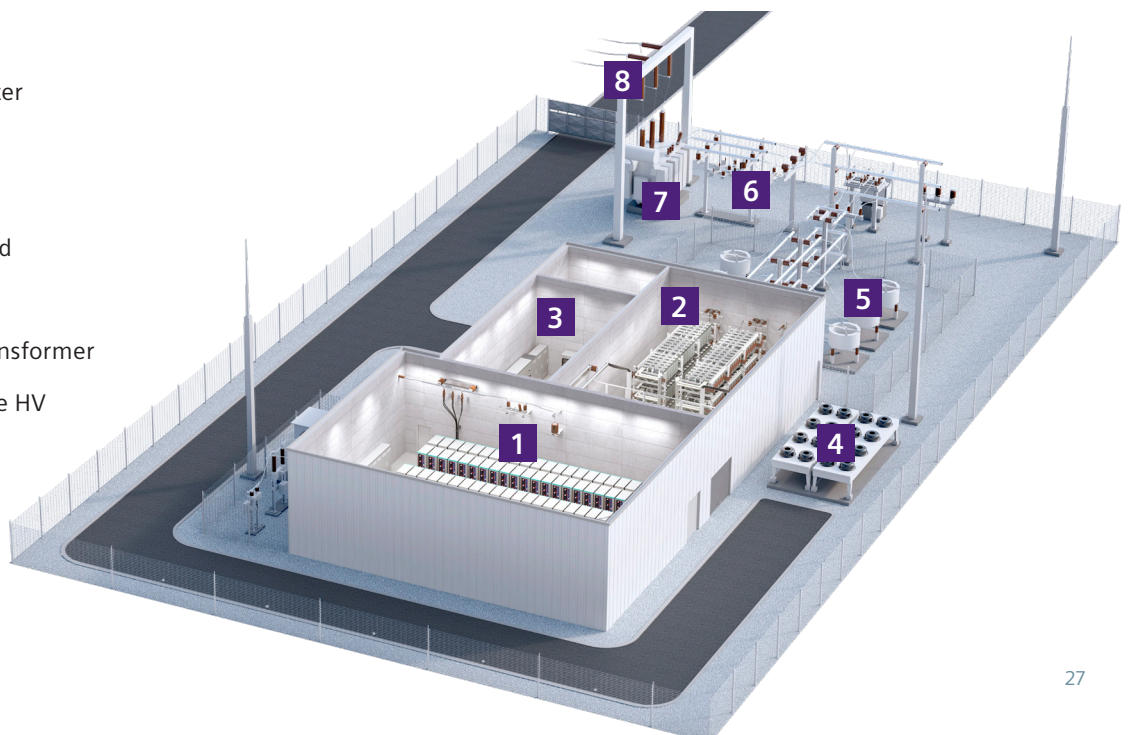

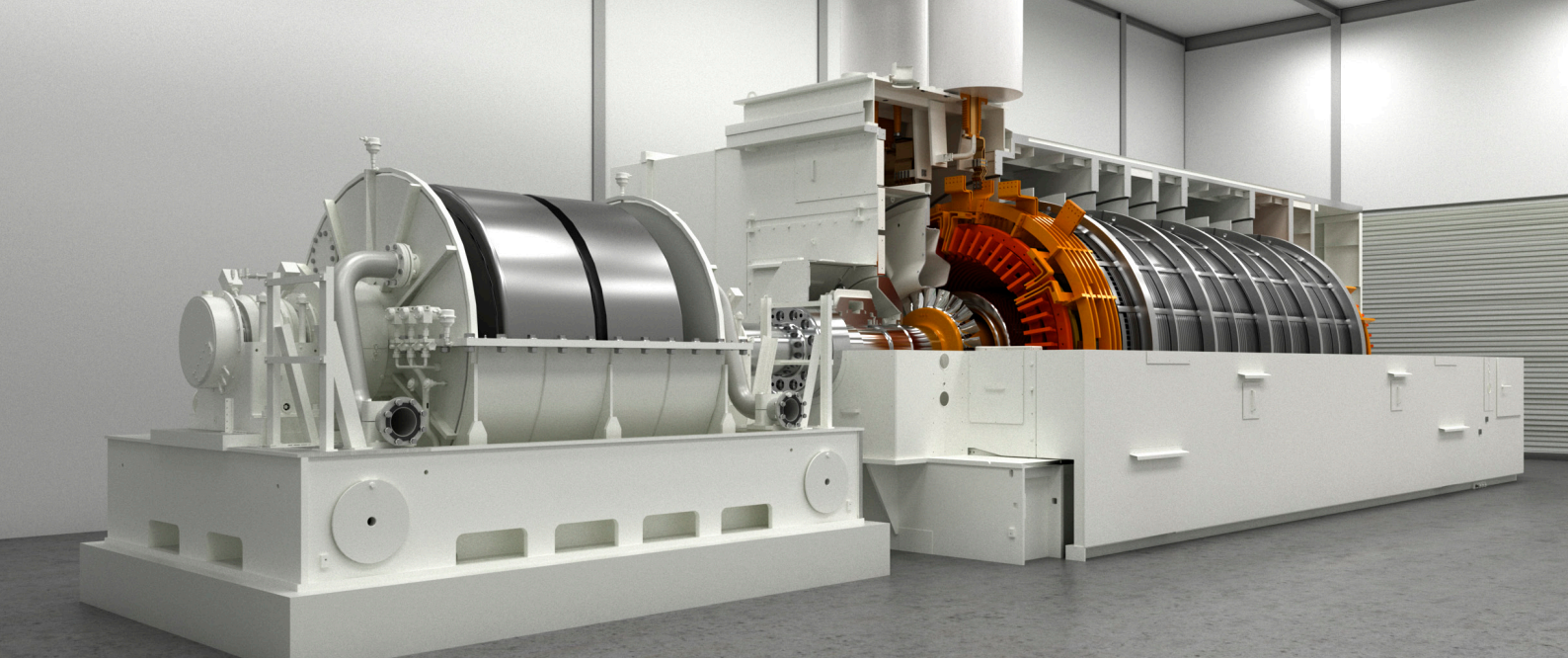

## 4.4 Synchronous Condenser

**With an increasing share of renewable power generation and the shutdown of large conventional and nuclear power plants for environmental, economic, social, and political reasons, most power grids are experiencing a decreasing level of inertia and short-circuit power.**

Inertia and short circuit power are integral factors for a capable system. Inertia reduces oscillation on grid frequency and prevents system blackouts, while short circuit power ensures reliable system protection.

Our synchronous condenser solution uses a generator to supply the necessary inertia with its rotating mass while also providing or absorbing reactive power. The generator is connected to the transmission network by a transformer and is started by a static frequency converter. Once the operating speed is achieved, the generator is synchronized with the network, behaving like a synchronous motor with no load and providing reactive power, short-circuit power, and inertia to the transmission network.

**In addition to that, grid operators face the following challenges:**

- Mostly non- synchronous, connected via power electronic converters
- Displace existing generation
- Located in remote parts of the grid
- Growing HVDC connections
- Growth of renewable generation



Contribution of short-circuit power



Voltage support



Short-term overload capability



Inertia to the transmission system

Benefits

### Maximum inertia with additional masses provided by flywheel solution

To provide maximum inertia, Siemens Energy has extended the synchronous condenser solution with additional rotating mass from a flywheel. This extension is a highly effective method to maintain the required level of inertia and rate of change of frequency (RoCoF) of the system.

Rotating mass provides an inherent synchronous inertial response, counteracting grid frequency fluctuations with active power injection or absorption during sudden load unbalance events.

Siemens Energy's flywheels operate in a partial vacuum to minimize air friction losses and reduce the cooling efforts to maintain required temperature levels in all operational and emergency modes. This design enables a safe emergency rundown in case of total power loss (grid blackout).

The flywheel is designed for plug-and-play installation delivered to the site with the rotor installed, allowing for a minimal footprint and low supervision and maintenance effort.

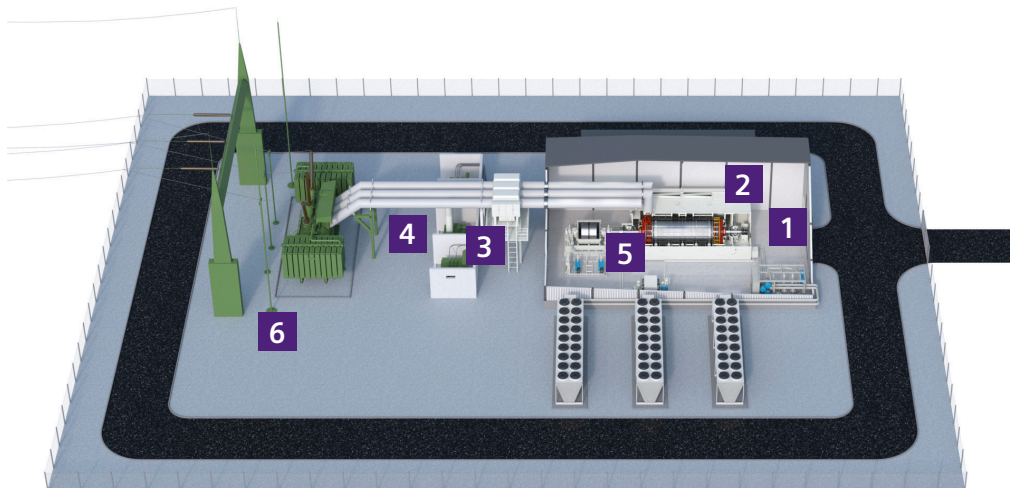

- 1** Generator hall
- 2** Synchronous generator
- 3** Generator circuit breaker
- 4** Auxiliary transformer
- 5** Flywheel
- 6** Power Transformer

#### Technical data

Reactive power range	Up to + 500/ -260 Mvar (@Generator terminal)
Terminal voltage	Up to 20 kV
Short circuit power range	Up to 2000 MVA
Inertia (kinetic energy)	Up to 4000 MWs



## 4.5 MVDC PLUS®

Regional HV and MV sub-transmission networks and MV distribution grids are pivotal in controlling the omnidirectional power flows characterizing current and future energy ecosystems. MVDC PLUS® manages the grid of the future.

### Reinforce MV transmission all the way

Transmission distances expand in increasingly liberalized markets. Growing infeed from distributed power generation units causes power quality and grid stability issues. Grid infrastructure expansion, upgrades, and reconnections are needed to meet the volatile demand for flexible electricity supply. Moreover, DSOs require a higher degree of transmission autonomy to fulfill today's wide-ranging tasks.

Siemens Energy's MVDC PLUS® is an efficient, robust, reliable, and compact solution that addresses these challenges by increasing transmission capabilities, strengthening the grid infrastructure, minimizing losses, and providing reactive power compensation and load flow control.

### Proven high-quality technology

MVDC PLUS® is based on Siemens Energy's renowned HVDC PLUS® technology. The symmetrical monopole layout represents the HVDC-to-topology slimmed down to its essential functionality. At the core are rugged and powerful multilevel VSCs that produce an almost ideal sinusoidal waveform to deliver consistent power quality. The converter stations allow for bidirectional power flow and can operate as STATCOMs.

Type	DNDC24	DNDC30	DNDC48
kVdc	+/- 24	+/- 30	+/- 50
kAdc	1.5	1.5	1.5
MW	70	90	149
Mvar	+/- 32	+/- 40	+/- 66
Km	50 ... 200	70 ... 300	100 ... 400



### Blackout prevention

- Supply remote locations
- Stabilize weak grids through coupling
- Flexible, programmable solution



### Grid utilization

- Increase power infeed
- Power exchange at MV- /
- Sub-transmission level



### Cost effective

- Lower costs at long distances
- No reactive power comp. needed
- Lower costs than fuel / power plants



### Lower environment impact

- No fuel & CO<sub>2</sub> emission
- Space saving

Benefits

## Wide-ranging transmission capabilities

MVDC PLUS® combines the best of AC and DC transmission:

- Simple design, robustness, reliability, and low costs of AC technology for seamless integration in existing transmission networks
- Long-distance transmission capabilities, high transmission capacity, active power flow control, reactive power compensation, and STATCOM properties of HVDC PLUS® technology

## Address all challenges in MV transmission simultaneously

The increasingly complex energy landscape poses several new challenges to regional transmission and distribution grids. MVDC PLUS® is the innovative, universal solution that handles all issues smoothly.

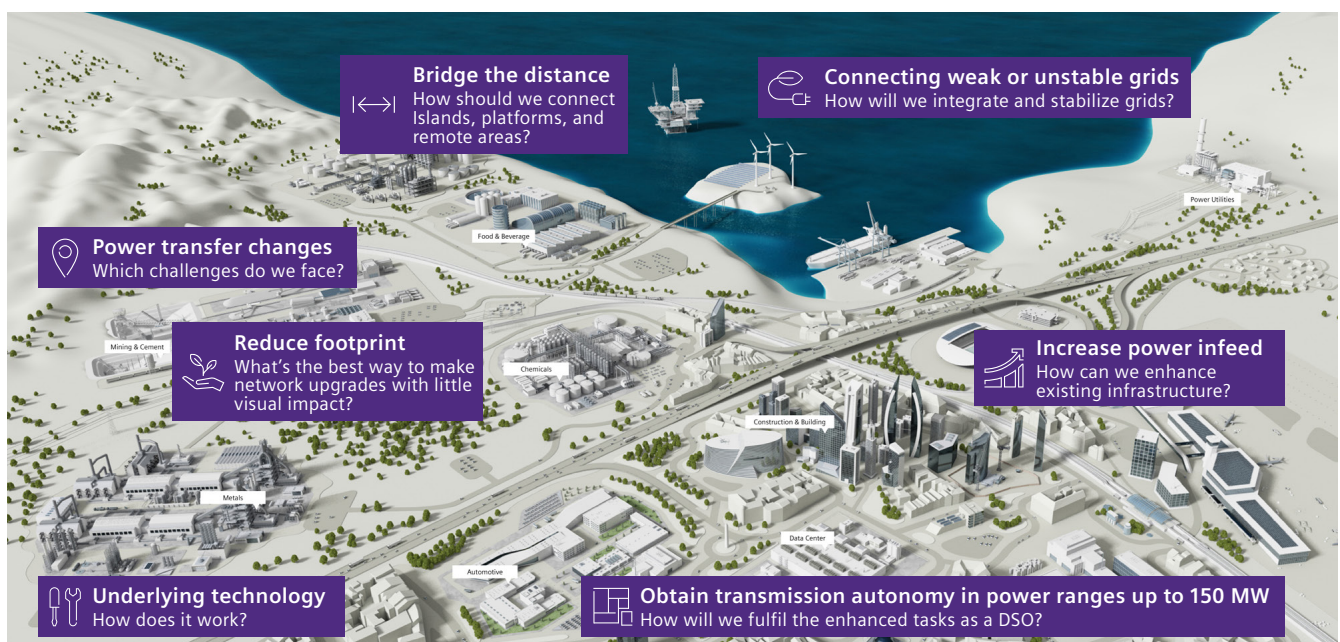

Managing the future grid: How to improve power transfer in the future grid?

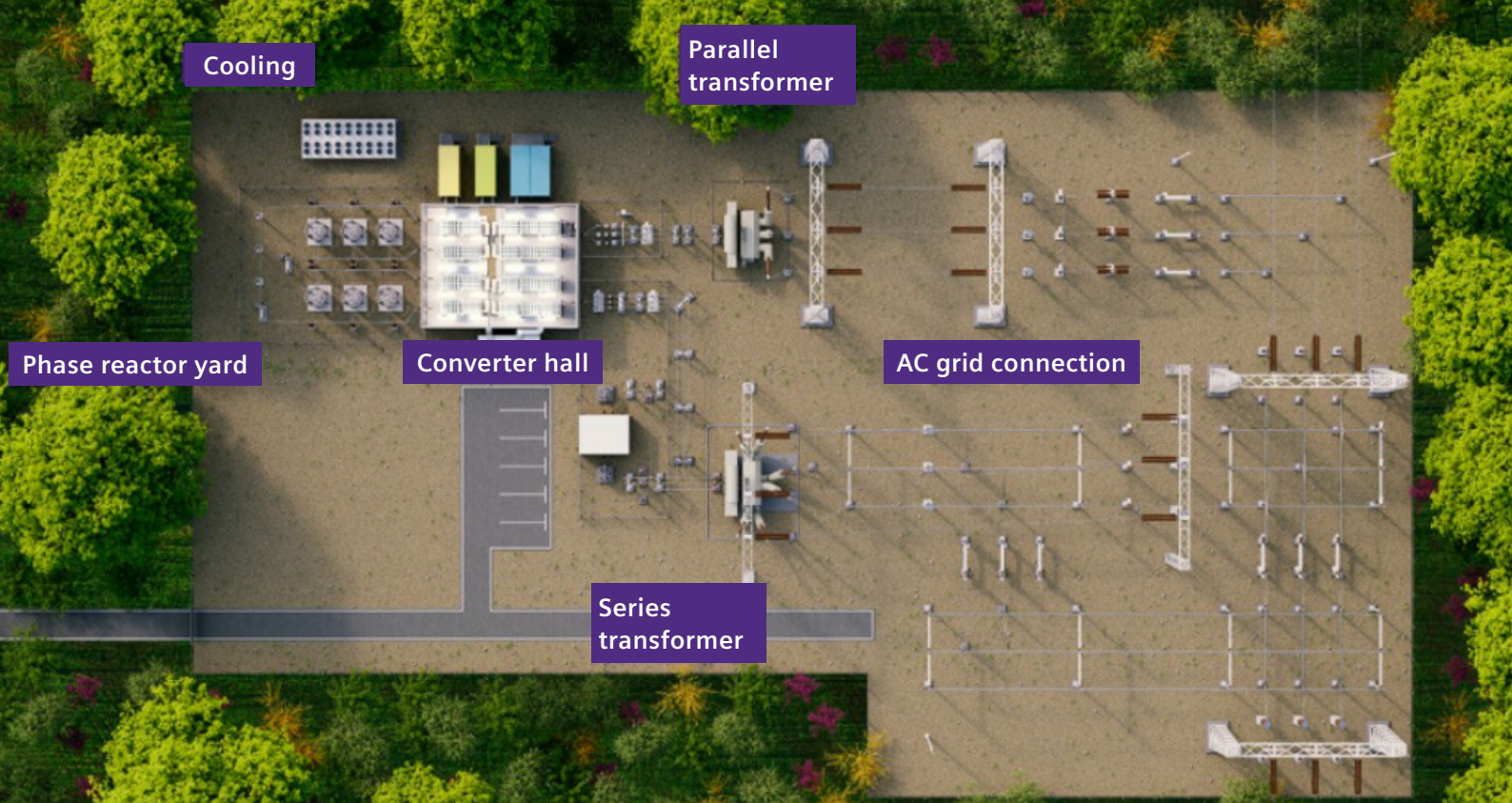

## 4.6 UPFC PLUS<sup>®</sup>

Enhances AC-grid through dynamic load flow control and lets you get the most from your existing grid capacity while maintaining maximum protection, reducing the risk of power failure, and minimizing redispatch costs.

### Fast, efficient, future-proof AC grid stabilization

As a global leader in power transmission technology and a long-standing, trusted partner of public utilities and grid operators, Siemens Energy has always been at the forefront of technical development. We have a long history of trendsetting in international power transmission projects that consistently demonstrate the reliability and quality of our products, solutions, and services. Energy ecosystems are in a state of profound change, yet reliable electricity is a fundamental societal requirement. Underdeveloped or weak grids, mature and aging infrastructure, and liberalized markets with a growing

share of alternative energy sources lead to associated business model disruption.

### Modern challenges for a legacy power grid

Increasingly decentralized energy systems and associated uncontrolled power flows pose new challenges for existing grid infrastructure. Thermal overloads in the lines and a growing number of cases where frequency and voltage come critically close to acceptable range limits – or even exceed them – threaten grid stability and the transmission infrastructure, often requiring costly redispatch intervention to address current and voltage factors.





**Dynamic**

With response time of milliseconds.

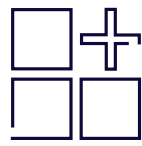

**Functional**

Load flow control and reactive power compensation in one solution.



**Flexible**

All system voltages can be addressed up to 500 kV



**Powerful**

Better utilization of existing infrastructure.



**Reasonable investment**

Lower investment compared to other solutions

Benefits

**UPFC PLUS® – the missing piece**

To manage the transmission system and provide stability and resilience, operators must better utilize existing assets. They can achieve this by employing a dynamic load flow management solution such as UPFC PLUS®, which has significantly faster reaction times and can manage both series and parallel compensation to keep lines within the N-1 criterion and the electricity flowing.

The **unified power flow controller** (UPFC) can balance load flow in the AC grid, rapidly bypass overloaded line sections, provide reactive power and dynamic voltage control, and utilize assets to physical limits without the need for safety margins.

The UPFC consists of two voltage sources: one in parallel to control the voltage and the other in a series connected to the AC line. This combination provides reactive power compensation, voltage control, and active power load flow control in one unit.

Compared to traditional power flow controllers, UPFC PLUS® controls power flow in milliseconds, stabilizing the AC grid even when critical situations suddenly develop (grid code N-1). UPFC PLUS® helps you get the most from your existing grid capacity while maintaining maximum protection, reducing power failure risk, and minimizing redispatch costs.

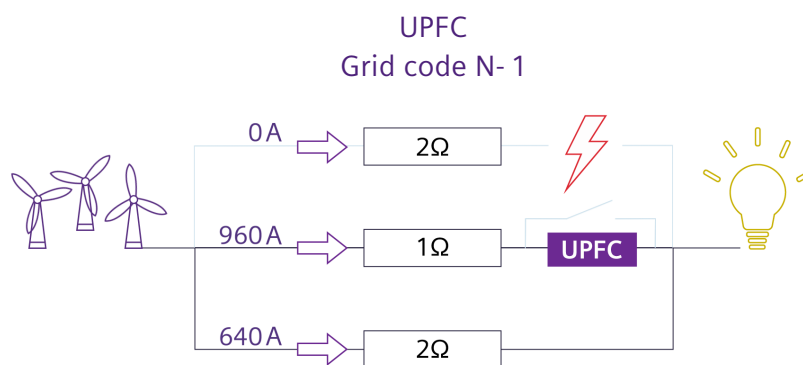



## 4.7 Fixed Series Capacitor

The ongoing energy system transformation requires effective means to address challenges in reliable power transmission. Instead of building new lines, our FACTS technology can increase transmission capacity. Series compensation technology provides higher transmission capacities for existing long-distance AC transmission lines and increased grid stability – without the costs and time requirements of building new lines.

### How to increase transmission system capacity and stability

The increasing energy demand can only be met when grids provide sufficient transmission capacity. Building new lines is not only expensive, but also complex due to changing regulations, public acceptance, and environmental concerns. Fixed series capacitor (FSC) technology provides an alternative solution by increasing the transmission capacity of existing lines.

### Proven fixed series capacitor technology for cost-effective capacity expansion

Power transfer with long overhead transmission lines is limited by the impedance that can lead to voltage drops. For decades, fixed series compensation has been the proven solution to maintain a minimum voltage profile and maximum utilization of transmission lines. This technology works by connecting a capacitor bank in series with the transmission line to partially compensate for inductive impedance while increasing the



### Increased maximum capacity

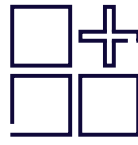

### Increased grid stability



### Economical solution

Benefits

voltage at the point of connection. The capacitors are protected by metal oxide varistors (MOVs) and – in case of a severe fault – by a breaker which bypasses the FSC. For instant protection, a triggered spark gap bypasses

capacitors and MOVs within less than 1 ms. Gapless solutions are also possible, provided that local requirements match. Due to this complexity, Siemens Energy offers individually designed solutions with FSCs.

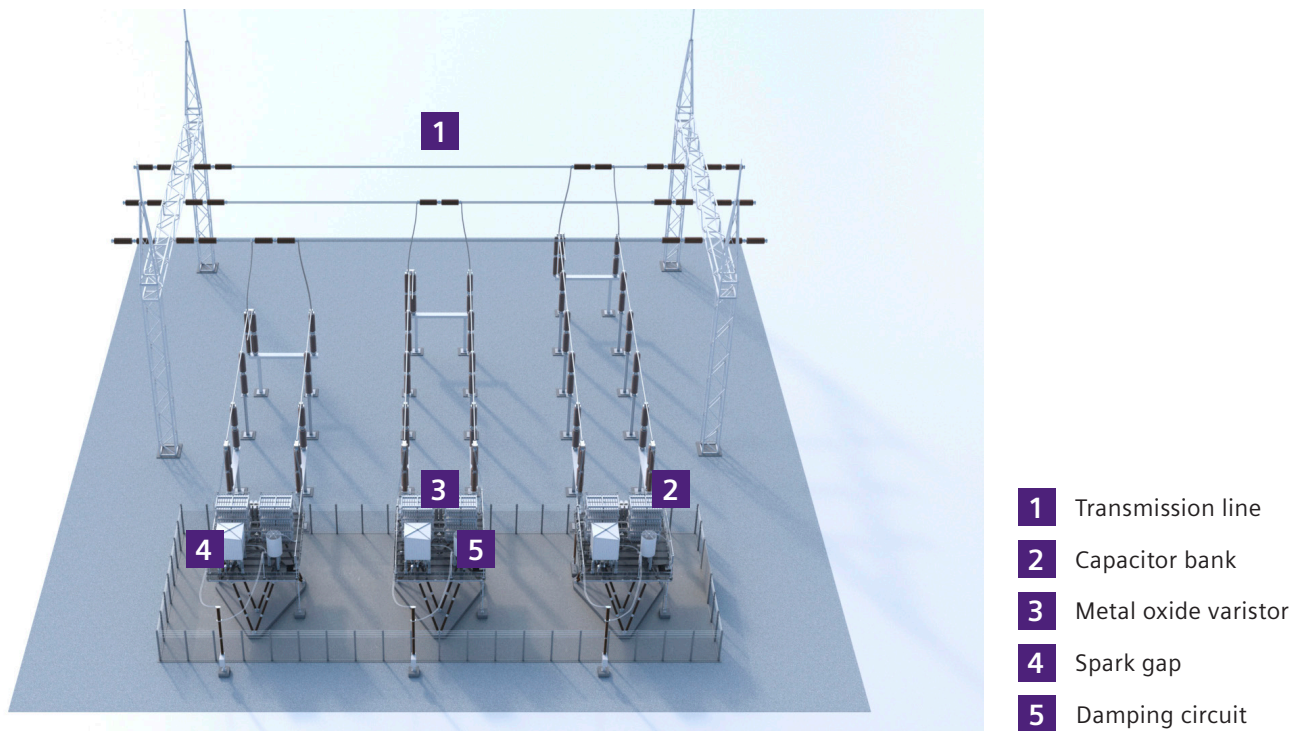

### Siemens Energy's advanced power delivery solution translates into many benefits:

- Increases power transfer capability
- Reduces line voltage drops
- Limits load-dependent voltage drops
- Influences load flow in parallel transmission lines
- Reduces transmission angle, increasing stability
- Reduces transmission systems footprint
- Cost-effective
- Reliable and robust design even in seismic areas

# 5. Global References







## 5.1 SVC PLUS® – Kriftel, Germany

### Reliable energy transmission by stabilizing the grid node in Rhine-Main

Commissioned by grid operator Amprion, the transmission systems by Siemens Energy support the power supply for the industrial city of Frankfurt in the Rhine-Main area. The reactive power compensation systems have been successfully running since 2018 for nearly 6 million inhabitants. Additionally, this power grid node supplies wind power from northern Germany to the industrial south.

Due to the energy transition in Germany, renewable and distributed energy sources increase power fluctuations. Amprion is responding by installing an SVC PLUS® system to stabilize grid

voltage during long-distance large-scale power transmission. Combined with a mechanically switched capacitor with damping network (MSCDN), these systems will help prevent gaps in supply due to large power plant shutdowns.

The SVC PLUS® system does not generate power but instead modulates and manages electricity that flows from sources hundreds of miles away. It can dynamically, rapidly, and flexibly increase or decrease grid voltage demand and effectively transmit electricity. At the core of SVC PLUS® is multilevel converter technology. Compared to other self-commutated converter topologies, the required space is reduced, and the system is ideal for flicker compensation, integration of wind power plants, and railway electrification.

#### Technical data

Customer	Amprion GmbH
Project name	Kriftel
Location	Germany
Scope	1x SVC PLUS®, 400 kV, ±300 Mvar
Special features	Voltage support Power transformer with DC compensation system
In service date	2019



## 5.2 SVC PLUS® – Sortland, Norway

### Dealing with the harsh environment to stabilize transmission in Norway

To improve the Norwegian power system and provide a reliable power supply, Statnett installed the SVC PLUS® by Siemens Energy.

The remoteness of the Lofoten Islands caused voltage instabilities on the existing HV line. Therefore, a fast compensation device was required close to the town of Sortland. Siemens Energy was awarded the SVC PLUS® contract since this solution featured several benefits for this case. Reducing local construction and

installation activities to a minimum and finishing the work before the early start of winter were the driving forces behind prefabricating as many system parts as possible. Also, the solution needed to deal with the harsh environment.

Accordingly, all electrical equipment was placed inside the SVC PLUS® containers, including the coupling reactors interconnected by cables. No active air-insulated parts were installed in the yard, which provided optimal protection, including vermin attacks. This solution also eliminated the need for an expensive and resource-consuming building.

#### Technical data

Customer	Statnett
Project name	Sortland
Location	Norway
Scope	1x SVC PLUS®, 132 kV, ±50 Mvar
Special features	Increase of power line transfer capability Voltage support Containerized phase reactors
In service date	2015

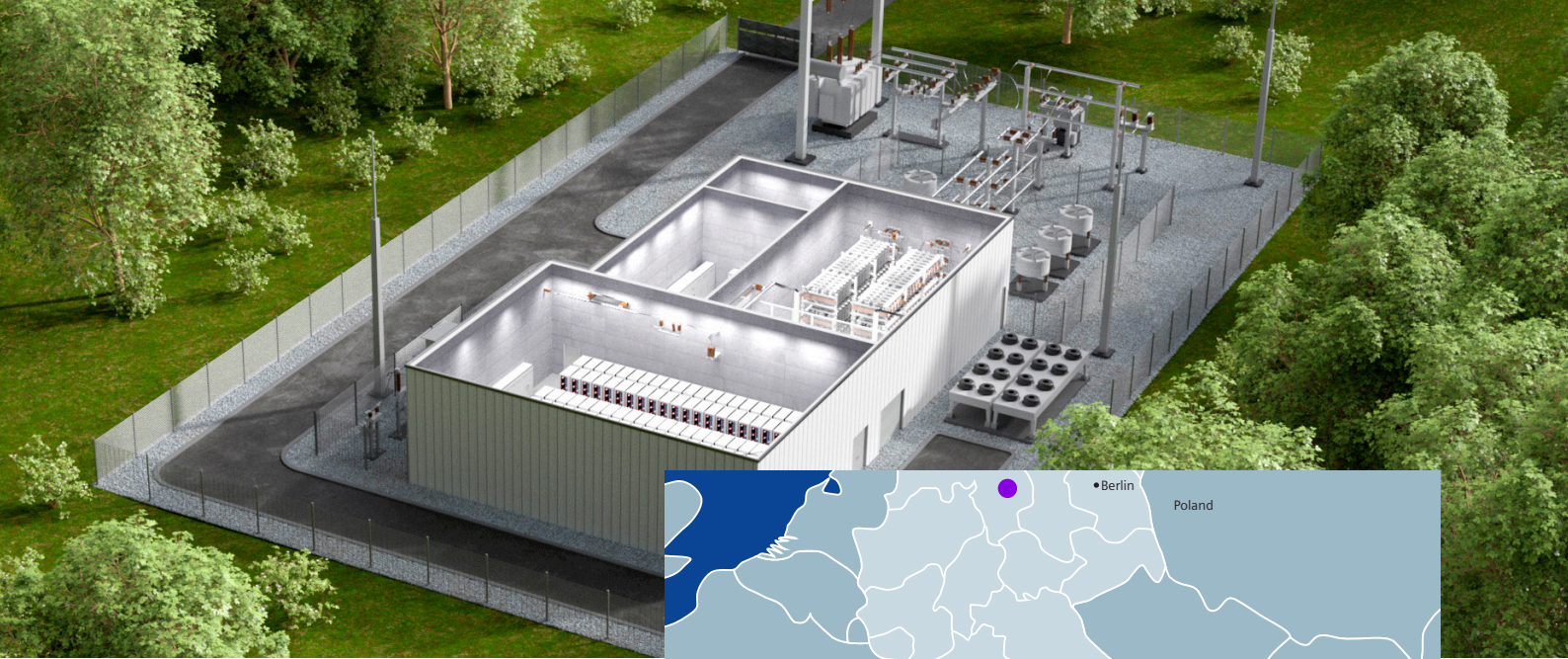

## 5.3 SVC PLUS FS<sup>®</sup> – Mehrum, Germany

### At the pulse of the energy transition: Grid stabilization in Germany

The German-Dutch transmission system operator TenneT has awarded Siemens Energy to install the world's first STATCOM with power supply system via supercapacitors. If more and more conventional power plants are taken off the grid and replaced by electricity from renewable energy sources, such plants are necessary.

By far the most onshore wind energy is produced in this location (Lower Saxony). Grid expansion is an important prerequisite for a reliable power supply. The project is scheduled to go into operation in 2025. The required energy is stored in supercapacitors in very

compact space, in a way that fluctuations of the grid frequency can be stabilized by charging or discharging of the stored 200 MW capacity.

Tim Holt, Member of the Managing Board at Siemens Energy: "The great strength of the European power grid is its resilience - it guarantees security of supply and thus also prosperity. To ensure that this remains the case in the future, investments in grid stability are extremely important. There is no time to lose, because energy transition does not just mean simply replacing fossil fuels with renewable energies. In the end, the electricity must also reach the consumers' sockets reliably. This is our drive for this project."

Technical data	
Customer	Tennet TSO GmbH
Project name	Mehrum Nord
Location	Germany
Scope	1x SVC PLUS Frequency Stabilizer <sup>®</sup> 400 kV -300/300 Mvar
Special features	First pilot worldwide, frequency stabilization and voltage support, active power by supercapacitors, emulates inertia very fast, active power input/ output, high power density, reactive power compensation
In service date	Est. 2025





## 5.4 SynCon – Robertstown, Australia

### The right momentum for grid stability

South Australian grid operator ElectraNet must deal with over 50% renewable energy in its grid – a formidable challenge for grid stability. The lack of inertia by heavy power turbines can instantaneously bridge sudden frequency drops. To avert the risk of blackouts, ElectraNet equipped its Robertstown substation with two generators with high-tech flywheels.

Synchronous condensers have long stabilized AC grids. Although they do not generate active current, they help balance reactive current, representing a characteristic of AC grids. Due to their large rotating masses, synchronous

condensers contribute a reasonable amount of inertia, but many grids need more. The flywheels also multiply the inertia and restore lost inertia in the Australian grid.

Although flywheels mean that synchronous condensers need to draw more current from the grid to remain in rotation, Siemens Energy developers have ensured that power losses for operating flywheels are as low as possible. The flywheels used in Robertstown rotate in a negative pressure close to a perfect vacuum. This innovation reduces frictional heat and energy losses – both would occur even if a surface as smooth as a mirror were turning in the air – by 90%.

<b>Technical data</b>	
<b>Customer</b>	ElectraNet Ltd.
<b>Project name</b>	Robertstown Substation
<b>Location</b>	Australia, South Australia
<b>Scope</b>	2x Turnkey SynCon incl. Flywheel at 275 kV
<b>Special features</b>	Short circuit power and inertia for system strength Flywheel connected to generator Condition based monitoring
<b>In service date</b>	2021



## 5.5 SynCon – Oberottmarshausen, Germany

### Stabilizing the power grid with reliable rotating phase shifters at Amprion

A central energy hub, the Oberottmarshausen substation distributes electricity to the south of Augsburg. The Dortmund transmission system operator, Amprion, commissioned a synchronous condenser by Siemens Energy for regional voltage maintenance in the power grid. As former large power generators are increasingly taken off the grid, Amprion is building reactive power compensation facilities such as the Rotating Phase Shifter in Oberottmarshausen as primary nodes in the power grid.

Siemens Energy (formerly Siemens AG) was awarded the construction contract for the rotating phase shifter and ancillary equipment at this substation. The shift in the power grid toward decentralized generators predominantly focuses on wind and solar plants. These changes present increasing challenges for long-term grid stability.

The rotating phase shifter can flexibly raise or lower grid voltage, allowing for precise regulation of future voltage in the transmission grid and the subordinate distribution grids. The valuable contribution of large thermal power plants to ongoing grid stabilization will increasingly switch to new technologies such as the rotating phase shifter from Siemens Energy.

Technical data	
Customer	Amprion GmbH
Project name	Oberottmarshausen
Location	Germany
Scope	1x SynCon, -200/+300 Mvar@400 kV
Special features	Provides short circuit power Condition based monitoring Implementation of SGen5-2000P generator
In service date	2018



## 5.6 SynCon - Moneypoint, Ireland

### The biggest flywheel in the world for a stable grid in the era of renewables

The progressive climate targets and the phase out coal put Ireland in a similar situation like other countries. The integration of additional renewable energy needs to be enabled. ESB, the leading Irish utility and owner of the Moneypoint powerplant, is currently working on transforming the site into a green energy hub.

The newly installed Synchronous Condenser including the flywheel is designed to use the existing grid connection. If conventional power generation is needed, block 2 of the powerplant will be connected. If additional renewables are

available, the synchronous condenser plant will be connected to stabilize the grid instead. Grid Stabilization is needed because the Irish Transmission System Operator Eirgrid is planning to use large wind farms to generate energy.

Since the turbines aren't connected directly to the grid, additional rotating mass is needed to keep the frequency stable. The installed flywheel at Moneypoint is the world's largest flywheel and the solution has a profound increased inertia capability. This allows more renewables to be fed into the Irish grid, because it supplies the same amount of rotation mass, inertia and short-circuit power as a coal turbine.

Technical data	
Customer	ESB generation and trading
Project name	Moneypoint
Location	Ireland
Scope	1x SynCon with flywheel -111/245 Mvar@400 kV, 4000 MWs
Special features	Biggest flywheel in the world
In service date	2023



## 5.7 FSC – Castanhal, Brazil

### Optimizing the transmission line in the Brazilian grid

With a dynamic increase in power generation in the north of Brazil and the need for increased transmission capacity, Siemens Energy was awarded the FSC contract in Castanhal.

The installation of this equipment on the transmission line presented several benefits to the system, customer TPE, and the citizens. Installing the FSC reduced the used space in the substation. Additionally, the project lead time was optimized compared to duplicating the

existing transmission line. Lastly, the environmental impact was decreased.

The FSC banks consist of capacitors and their protection devices are installed on the same potential of the transmission line voltage. Therefore, they must be isolated from the ground. For this, the equipment is mounted on a metal platform containing iron, steel, and aluminum structures, supported by insulators dimensioned for the voltage level of the transmission line. Another protection device for the FSC bank is the bypass circuit breaker – the only high-voltage equipment not installed on the platform.

Technical data	
Customer	TPE
Project name	Castanhal
Location	Brazil
Scope	1x FSC, 230 kV, 151 Mvar
Special features	70% compensation degree
In service date	2012



## 5.8 FSC – Hirvisuo, Finland

### Flexibility in the grid by using fixed series compensation

A significant amount of Finland’s power is generated in the north by hydropower plants and wind power. The Finish grid is connected to Sweden and Norway by AC interconnectors in the north. The main challenge of Finland’s grid operator, Fingrid, is to transport a large amount of energy from the north to the south, where most of the power is consumed.

To tackle this challenge, Fingrid upgraded their Rannikkolinja line (coastal line) from Turku to Oulu from 220 kV to 400 kV. Since studies show that system limits are defined by voltage stability and not thermal overload, fixed series compensation is the optimal solution. This technology applies capacitive reactive power and compensates for the inductive portion of transmission losses. The alternative would be a newly built line, but the investment cost, environmental impact, project complexity, and feasibility are all considerably lower in fixed series compensation.

Technical data	
Customer	Fingrid Oyi
Project name	Hirvisuo
Location	Finland
Scope	2x Turnkey FSC, 400 kV, 160 Mvar, and 232 Mvar
Special features	Tailored to ambitious climate conditions
In service date	2016



## 5.9 FSC – Polpaico, Chile

### Reliability in a high seismic area

Chile’s energy transition strategy has evolved in recent years. Their goal is to convert 70% of their total energy consumption to renewables by 2030 and pledged to become carbon neutral by 2050. In Polpaico, Siemens Energy Fixed Series Capacitors (FSC) help to improve their transmission capacity and system transient stability. Instead of building new lines to provide sufficient transmission capacity, it’s often better to use our Flexible AC Transmission Systems (FACTS) technology.

Since the FSC is connected in series to the transmission line, all the equipment is installed at a steel platform at the same voltage level of the grid – in this case, 500 kV. For safety reasons,

the platform needed to be isolated from the ground level with post insulators of the corresponding voltage level, which withstands the weight of all equipment.

The solution has a specific design called V-Shape, which reduces the number of foundations and insulators needed. Additionally, the project is located in a high seismic area. Due to these conditions, it became even more of a challenge by increasing the design complexity and site works requirements to assure that the steel platform would withstand the strongest force and influence conditions of this

Technical data	
Customer	ISA Interchile
Project name	DS422 Project
Location	Polpaico
Scope	2x FSC 550 kV 336,4 Mvar
Special features	High seismic design, Industry application
In service date	2020



## Published by

Siemens Energy Global GmbH & Co. KG  
Transmission  
Siemenspromenade 9  
91058 Erlangen  
Germany

For the U.S. published by  
Siemens Energy, Inc  
Transmission  
4601 Six Forks Road  
Raleigh, NC 27609  
USA

For more information, please visit our website:  
[siemens-energy.com/facts](https://www.siemens-energy.com/facts)

or contact us: [factsinfo.energy@siemens-energy.com](mailto:factsinfo.energy@siemens-energy.com)

© Siemens Energy, 2023

Subject to changes and errors. The information given in this document only contains general descriptions and/or performance features which may not always specifically reflect those described, or which may undergo modification in the course of further development of the products. The requested performance features are binding only when they are expressly agreed upon in the concluded contract. All product designations may be trademarks or product names of Siemens Energy Global GmbH & Co. KG or other companies whose use by third parties for their own purposes could violate the rights of the owners.

Siemens Energy is a trademark licensed by Siemens AG.